

STEAMER 2 LEVEL



MODEL WST3003ZE

OWNER'S MANUAL



Westinghouse

IMPORTANT SAFEGUARDS

When using electrical appliances, basic safety precautions should always be followed including the following:

1. Read all instructions.
2. Do not touch hot surfaces. Use handles or knobs.
3. To protect against electrical shock do not immerse cord, plugs, or appliance in water or other liquid.
4. Close supervision is necessary when any appliance is used by or near children.
5. Unplug from outlet when not in use and before cleaning. Allow to cool before putting on or taking off parts.
6. Do not operate any appliance with a damaged cord or plug or after the appliance malfunctions or has been damaged in any manner. Contact Consumer Service for examination, repair or adjustment.
7. The use of accessory attachments not recommended by the appliance manufacturer may cause injuries.
8. Do not use outdoors.
9. Do not let cord hang over edge of table or counter, or touch hot surfaces.
10. Do not place on or near a hot gas or electric burner, or in a heated oven.
11. Extreme caution must be used when moving an appliance containing hot oil or other hot liquids.
12. To disconnect turn to "O" and remove plug from wall outlet.
13. Do not use appliance for other than intended use.

SAVE THESE INSTRUCTIONS

For Household Use Only

ADDITIONAL IMPORTANT SAFEGUARDS

CAUTION HOT SURFACES: This appliance generates heat and escaping steam during use. Proper precautions must be taken to prevent the risk of burns, fires, or other injury to persons or damage to property.

1. A person who has not read and understood all operating and safety instructions is not qualified to operate this appliance. All users of this appliance must read and understand this Owner's Manual before operating or cleaning this appliance.
2. **Unplug from outlet when not in use and before cleaning. To avoid electric shock, never immerse or rinse this appliance in water or any other liquid.**
3. If this appliance falls or accidentally becomes immersed in water, unplug it from the wall outlet immediately. **Do not reach into the water!**
4. When using this appliance, provide adequate air space above and on all sides for air circulation. Do not operate this appliance while it is touching or near curtains, wall coverings, clothing, dishtowels or other flammable materials.
5. To reduce the risk of fire, do not leave this appliance unattended during use.
6. If this appliance begins to malfunction during use, immediately unplug the cord. Do not use or attempt to repair a malfunctioning appliance!
7. The cord to this appliance should only be plugged into a 120V AC electrical wall outlet.
8. Do not use this appliance in an unstable position.
9. Use potholders or oven mitts to remove Lid, Steaming Bowl and Rice Bowl.
10. Do not operate appliance while empty or without water in the reservoir.
11. Lift and open Cover carefully to avoid scalding and allow water to drip into steamer.
12. Use extreme caution when moving appliance containing hot food.

POLARIZED PLUG

This appliance has a polarized plug (one blade is wider than the other). To reduce the risk of electric shock, this plug is intended to fit into a polarized outlet only one way. If the plug does not fit fully in the outlet, reverse the plug. If it still does not fit, contact a qualified electrician. Do not attempt to modify the plug in any way.

SHORT CORD INSTRUCTIONS

A short power-supply cord is provided to reduce the risk resulting from becoming entangled in or tripping over a longer cord.

Longer detachable power-supply cords or extension cords are available and may be used if care is exercised in their use.

If a longer detachable power-supply cord or extension cord is used, (1) the marked electrical rating of the cord set or extension cord should be at least as great as the electrical rating of the appliance, and (2) the cord should be arranged so that it will not drape over the countertop or tabletop where it can be pulled on by children or tripped over unintentionally.

ELECTRIC POWER

If the electrical circuit is overloaded with other appliances, your appliance may not operate properly. It should be operated on a separate electrical circuit from other appliances.

PLASTICIZER WARNING

CAUTION: To prevent Plasticizers from migrating from the finish of the countertop or tabletop or other furniture, place **NON-PLASTIC** coasters or placemats between the appliance and the finish of the countertop or tabletop.

Failure to do so may cause the finish to darken, permanent blemishes may occur or stains can appear.

GETTING TO KNOW YOUR WESTINGHOUSE WST3003ZE STEAMER 2 LEVEL

PRODUCT MAY VARY SLIGHTLY FROM ILLUSTRATION

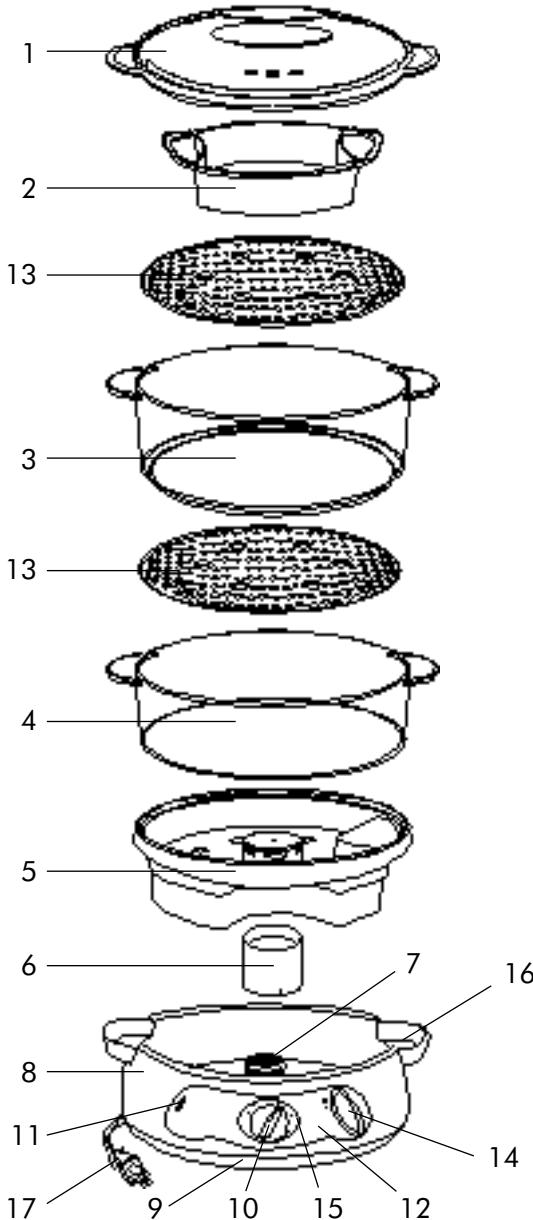

1. Lid (P/N22278)
2. Rice Bowl (P/N22279)
3. Large Steaming Bowl (P/N22280)
4. Small Steaming Bowl (P/N22281)
5. Drip Tray (P/N22282)
6. Removal Ring (P/N22283)
7. Heater Element
8. Base
9. Base Cover
10. Knob
11. Lamp Cover
12. Timer Cover
13. Removable Grid (P/N22284)
14. Water Level Indicator
15. Deco Ring
16. Water Filling
17. Polarized Plug

BEFORE USING FOR THE FIRST TIME

1. Carefully unpack the Food Steamer.
2. Remove any labels or stickers from appliance.
3. Thoroughly wash lid, rice bowl, large steam bowl, small steam bowl, drip tray, removable grids, and removable ring, in warm soapy water before first use then rinse and dry carefully. **NEVER IMMERSE BASE IN WATER.**
4. Wipe the inside of the base with a damp cloth.

INSTANT STEAM FUNCTION

There is a removable heating element ring included. If you place this ring on top of the heating element before cooking, this instant steam function will produce steam in 35 seconds.



Please note there is a small cut on the heating element ring which should be faced downward when you place it on top of the heating element.

OPERATING INSTRUCTIONS

1. Place unit on a flat sturdy surface with adequate clearance (i.e. do not place under wall cabinets). The steamer unit and components are not for use in ovens (microwave, convection or conventional) or on stove-top.
2. Put the removable ring around the heater element.
3. Fill water reservoir with clean water only. Do not put any other liquids or add any salt, pepper, etc. in the water reservoir.
4. Make sure the water does not exceed the MAX fill level as indicated near the Water Level Indicator.
5. There are two possible methods to fill the water reservoir.
 - Pour cold water into the water reservoir through the water filling device.
 - Pour cold water directly into the water reservoir and heating element housing.
6. Place the DRIP tray on the base.

OPERATING INSTRUCTIONS (Cont.)

TO USE LARGE OR SMALL STEAM BOWL

Place any one steam bowl of two in top of drip tray and base. Place vegetable, seafood or other foods without sauce or liquid in steam bowl. Try not to block steam vents.

TO USE LARGE AND SMALL STEAM BOWLS

Place the larger piece of food with the longer cooking time in small steam bowl then place on top of drip tray and base. Place the large steam bowl on the small steam bowl.

TO USE REMOVABLE GRIDS

The bowls are fitted with removable grids which increase the volume of cooking area and can be used to cook large items of food.

TO USE RICE BOWL

Place rice or other foods with sauce or liquid in rice bowl. Place the rice bowl in the steaming bowl. Cover with lid. Plug into wall outlet and set timer. When food is well cooked, unplug unit.

COOKING EGGS

Place the eggs directly into the drip tray or the removable grid using the especially shaped holes provided for this purpose. Cover with lid.

WHEN HANDLING AND REMOVING HOT COMPONENTS, USE POT-HOLDERS TO AVOID BURNS FROM HOT STEAMS.

TIMER SETTING

Mechanical Type

Set the timer to the recommended cooking time (steaming time can be adjusted as per your experimenting). The light turns on and steam comes in 35 seconds if using heater element ring. The light will turn off when cooking is completed and the timer will give a signal bell.

USER MAINTENANCE INSTRUCTIONS

Unplug cord from outlet. Before cleaning allow steamer to cool. Never immerse the base, cord and plug in water.

1. Empty the drip tray and the water reservoir.
2. Wash lid, steam bowls, removable grids, rice bowl and drip tray in hot soapy water, rinse and dry all parts. Or wash on top rack of dishwasher.
3. Clean reservoir with soapy water then wipe with damp cloth.
4. Do not use abrasive cleaners.
5. The small steaming bowl and the rice bowl can be stored inside the large steam bowl with the lid on top of all three.
6. In hard water areas, the scale may build up on the heating element. If scale is allowed to accumulate, the steam could turn off before the food is cooked. So, after 7-10 uses, pour 3 cups clear vinegar into the water reservoir then fill water up to HI level. Do not place lid, steaming bowl, rice bowl & juice tray in this procedure.
7. Plug in and set timer up to 20 minutes. When the timer rings, unplug cord from outlet. Allow the unit to cool completely before emptying the water reservoir. Use cold water to rinse the water reservoir several times.
8. Use potholders or oven mitts to remove lid, steam tray and rice bowl.

RECIPES

RICE & GRAINS

1. There are many types of rice. Follow specific directions for variety used.
2. Accurately measure the rice and water then combine in rice bowl. Pour specified amount of water in water reservoir. Cover and steam.
3. For softer rice, increase 1-2 tablespoons water mixed with rice by the specified amount of water on the chart. For firmer rice decrease water mixed with rice by the same amount.
4. Check doneness and consistency of rice at the minimum time specified for each type, stirring rice at the same time.
5. When checking/stirring rice, be careful not to drip the condensate into the rice bowl which would reduce the quality and flavor of the steamed rice.
6. Use only clean water in water reservoir.
7. Rice may be seasoned with salt, pepper or butter after steaming.

Type of Rice	Combined to Rice Bowl		Approx. Time (Minutes)
	Amt. Rice	Water	
Brown			
• Regular	1/2 cup	1 cup	42-45
• Parboiled	1 cup	1 1/2 cups	45-50
Long Grain and Wild Rice Mix			
• Regular (6 oz pkg)	Mix	1 1/4 cups	35-45
• Quick Cooking (6.2 oz pkg)	Mix	1 1/2 cups	18-20
• Instant	1 cup	1 1/2 cups	12-15
White			
• Regular	1 cup	1 1/2 cups	45-50
• Long Grain	1 cup	1 2/3 cups	50-55

*Approximate times are offered as guidelines only. Cooking times may vary.

RECIPES

VEGETABLES

1. Clean the vegetables thoroughly. Cut off stems, trim, peel or chop if necessary. Smaller pieces steam faster than larger ones.
2. Quantity, quality, freshness, size/uniformity, and temperature of frozen food, may affect steam timing. Adjust water amounts and cooking time as desired.
3. Frozen vegetables should not be thawed before steaming.
4. Some frozen vegetables should be placed in the rice bowl and covered with a piece of aluminum foil during steaming. The frozen foods should be separated or stirred after 10-12 minutes using a long handle fork or spoon.

Variety	Weight/or Number of Pieces	Approx. Time (Minutes)
Artichokes, whole	4 Whole tops trimmed	30-32
Asparagus, Spears	1 pound	12-14
Beans, Green/wax	¹ / ₂ pound	12-14
Cut or whole	1 pound	20-22
Beets	1 pound cut	25-28
Broccoli, Spears	1 pound	20-22
Brussel Sprouts	1 pound	24-26
Cabbage	1 pound sliced	16-18
Celery	¹ / ₂ pound thinly sliced	14-16
Carrots	1 pound thinly sliced	18-20
Cauliflower, Whole	1 pound	20-22
Corn on the Cob	3 ¹ / ₂ pounds	14-16
Eggplant	1 pound	16-18
Mushrooms Whole	1 pound	10-12
Okra	1 pound	18-20
Onions	¹ / ₂ pound thinly sliced	12-14
Parsnips	¹ / ₂ pound	8-10
Peas	1 pound shelled	12-13
Peppers, Whole	up to 4 medium (not stuffed)	12-13
Potatoes, Whole-Red	1 pound (about 6 small)	30-32
Rutabaga	1 medium diced	28-30
Spinach	¹ / ₂ pound	14-16
Squash		
• Summer Yellow and Zucchini	1 pound sliced	12-14
• Winter Acorn and Butternut	1 pound	22-24
Turnips	1 pound sliced	20-22
All Frozen Vegetables	10 ozs.	15-30

RECIPES

FISH AND SEAFOOD

1. The steaming times listed in the chart are for fresh or frozen and fully thawed seafood and fish. Before steaming, clean and prepare fresh seafood and fish.
2. Most fish and seafood cook very quickly. Steam in small portions or in amounts as specified.
3. Clams, oysters and mussels may open at different times. Check the shells to avoid overcooking.
4. You may steam fish fillets in the rice bowl. Serve steamed seafood and fish using plain or seasoned butter or margarine, lemon or favorite sauces.
5. Adjust steaming times accordingly.

Variety	Weight/or Number of Pieces	Approx. Time (Minutes)
Clams in shell		
• littlenecks/cherrystones	1 pound	10-12
Crab		
• King Crab, legs/claws	1 pound	20-22
• Soft Shell	8-12 pcs	8-10
Lobster		
• Tail	2-4	16-18
• Split	1 - 1 ^{1/4} pounds	18-20
• Whole, Live	1 - 1 ^{1/4} pounds	18-20
Mussels (fresh in shell)	1 pound	14-16
Oysters (fresh in shell)	3 pounds	18-20
Scallops (fresh)		
• Bay (shucked)	1 pound	14-16
• Sea (shucked)	3 pounds	18-20
Shrimp		
• Medium in shell	1 pound	10-12
• Large jumbo in shell	1 pound	16-18
Fish		
• Whole	1/2 to 1/2 pound	10-12
• Dressed	1/2 to 1/2 pound	12-15
• Filets	1 pound	12-18
• Steaks	1/4 inch thick	10-12

RECIPES

EGGS

Variety	Weight/or Number of Pieces	Approx. Time (Minutes)
In the shell		
• Soft-Cooked	1-12	15-18
• Hard-Cooked	1-12	19-22
“Eggs-in-a-Cup”		
Crack raw egg into custard cup. Season with salt, pepper and butter or margarine, if desired.		
• Soft-Cooked	1-4	10-12
• Hard-Cooked	1-4	12-14
Poached		
Step one: Pour 2 cups water in rice bowl. Steam to heat water.		7-8
Step two: Crack egg in small bowl, slide into hot water in rice bowl. Steam until poached.		7-8
Scrambled		
Beat 6 eggs together and 2 tablespoons of milk in rice bowl. Season with salt and pepper. Stir eggs halfway through cooking.		20-22

RECIPES

MEAT & POULTRY

Variety	Weight/or Number of Pieces	Approx. Time (Minutes)
Beef		
• Chuck	1 pound	28-30
• Hamburger	1 pound	16-18
• Meatballs	1 pound	22-24
Chicken	1 pound	
• Pieces	(2-4 pcs)	24-26
Lamb		
• Cubes	1 pound	26-28
Pork		
• Cubes	1 pound	26-28
Hot Dogs	1 pound	14-18
Pre-Cooked Sausage	1 pound	14-18

REHEATING: BREADS AND LEFTOVERS

1. Do not wrap or cover when reheating breads.
2. For leftovers, reheating times are based on foods at refrigerator temperatures.
3. When reheating leftovers in the rice bowl, always spread leftovers evenly in the rice bowl and use aluminum foil to cover.
4. Experiment with your own leftovers.

LIMITED ONE YEAR PRODUCT WARRANTY

Warranty: This product is warranted to be free from defects in materials and workmanship for a period of one (1) year from the original purchase date. This product warranty covers only the original consumer purchaser of the product.

Warranty Coverage: This warranty is void if the product has been damaged by accident in shipment, unreasonable use, misuse, neglect, improper service, commercial use, repairs by unauthorized personnel, normal wear and tear, improper assembly, installation or maintenance abuse or other causes not arising out of defects in materials or workmanship. This warranty is effective only if the product is purchased and operated in the USA or Canada, and does not extend to any units which have been used in violation of written instructions furnished with the product or to units which have been altered or modified or to damage to products or parts thereof which have had the serial number removed, altered, defaced or rendered illegible.

Implied Warranties: ANY WARRANTIES IMPLIED WHICH THE PURCHASER MAY HAVE ARE LIMITED IN DURATION TO ONE (1) YEAR FROM THE DATE OF PURCHASE. Some states and provinces do not allow limitations on how long an implied warranty lasts, so the above limitation may not apply to you.

Warranty Performance: During the above one-year warranty period, a product with a defect will be either repaired or replaced with a comparable model when the product is returned to Zellers. The repaired or replacement product will be in warranty for the balance of the one-year warranty period and an additional one-month period. No charge will be made for such repair or replacement within the warranty period.

Important Notice: If any parts are missing or defective, return this product to the place of purchase.

Any questions or comments can be directed to the Consumer Relations Department. Please write to or call:

Consumer Relations Dept.
P.O. Box 6916
Columbia, MO 65205-6916
1(800) 233-9054

Limitation of Remedies: No representative or person is authorized to assume for us any other liability in connection with the sale of our products. There shall be no claims for defects or failure of performance or product failure under any theory of tort, contract or commercial law including, but not limited to negligence, gross negligence, strict liability, breach of warranty, and breach of contract. Repair, replacement or refund shall be the sole remedy of the purchaser under this warranty. Some states and provinces do not allow the exclusion or limitation of incidental or consequential damages, so the above limitation or exclusion may not apply to you.

Legal Rights: This warranty gives you specific legal rights, and you may also have other rights which vary from state to state/province.

WESTINGHOUSE™, and "YOU CAN BE SURE...IF IT'S WESTINGHOUSE™" are trademarks of WESTINGHOUSE ELECTRIC CORPORATION and used under license by Salton, Inc. **In no event shall Salton, Inc. be liable for any incidental or consequential damages, losses or expenses.**

Made in China

"© 2003
All Rights Reserved"

P/N 61321
Printed in China